

Assembly of the Clear Solutions® Slatwall Spinner

1.

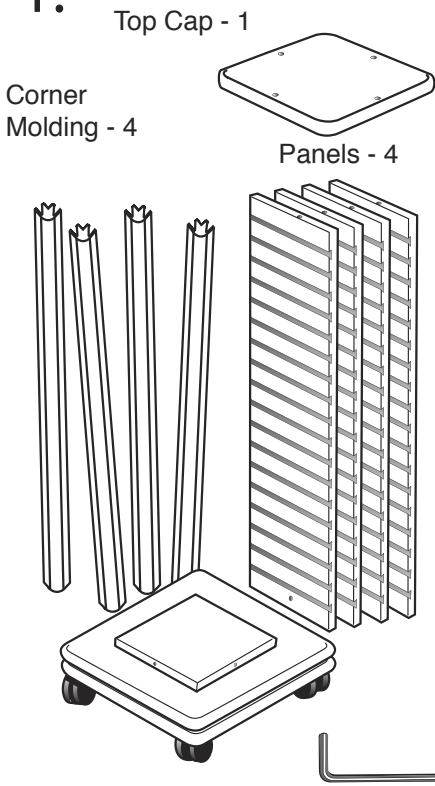

1. Carefully unpack shipping boxes and locate all parts before beginning assembly.

2. Position two panels with the slots facing out and the through holes on the bottom. Slide one of the corner moldings over the panels. Continue with another panel and another corner molding.

3. When all four panels and moldings are together, carefully pick the assembly up and place it on the base. Attach the panel assembly to the base using four of the included screws.

4. Attach the top to the panels using the four remaining screws.

5. Fit shelves and accessories to the fixture.

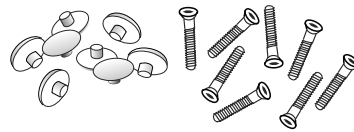

2.

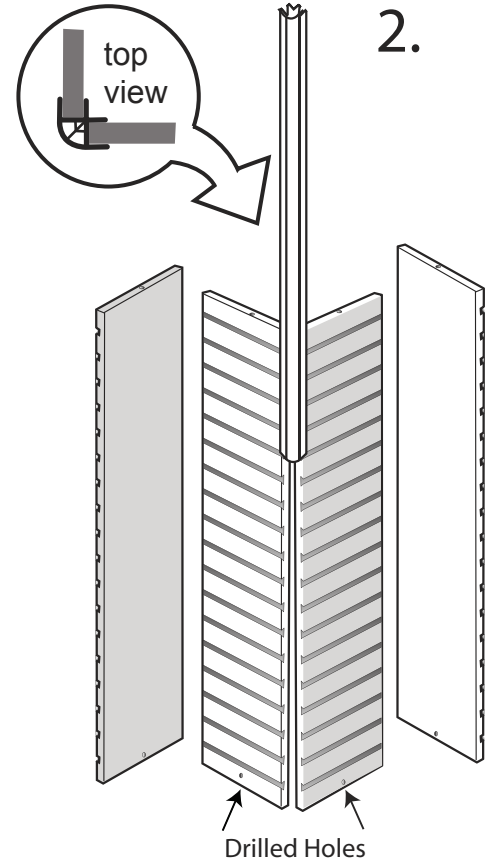

Base Unit - 1

Allen Wrench (1)

Screws & covers - 8

Drilled Holes

3.

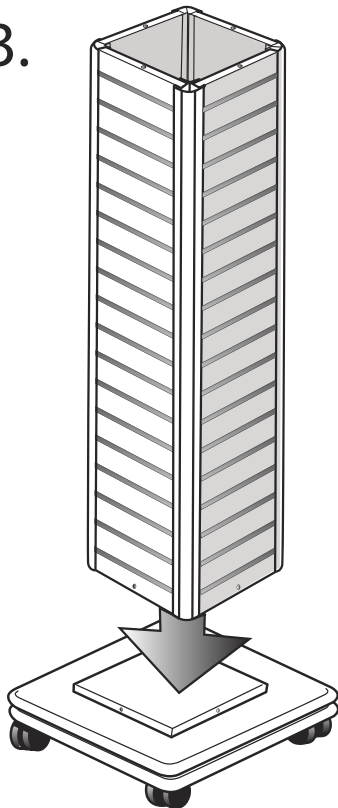

4.

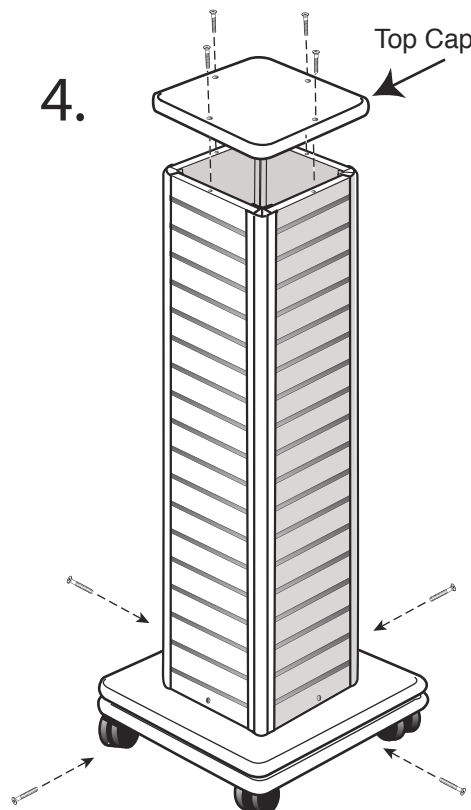

5.

