

Assembly of the Clear Solutions® Spinner Base #8435

1. Unpack and locate all parts.

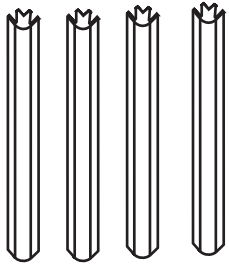

Corner Molding - 4

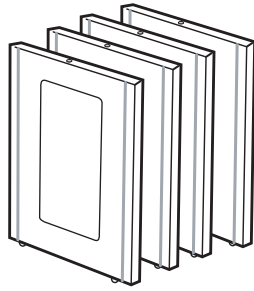

Panels - 4 (1 w/door)

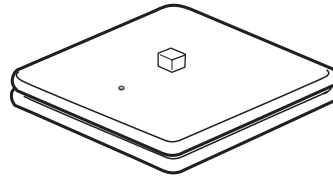

Turntable top

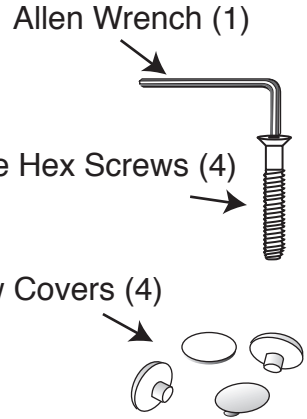

2. Position two slotted Panels with the slots to the inside and the Plastic Feet on the bottom as shown.

3. Slide one of the Corner Moldings over the panels so that the plastic spline locks into the slot. Continue with another panel and another corner molding until all 4 panels are joined together.

top view

Plastic feet

Position Top Assembly over Base Panels

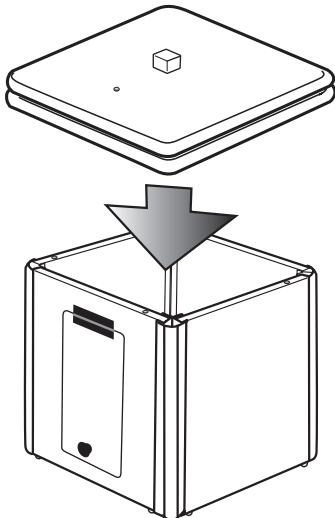

4. When all four panels and moldings are together, place the Turntable assembly in place on top of the panels.

5. Now rotate the turntable top until you expose the 4 drilled holes (approx 45 degrees). Attach the top cap to the panels using the four screws and the allen wrench provided. Press the plastic screw covers onto the screws.

