

Assembly of the Plywood Counter Spinner

1. Carefully unpack and locate all parts before beginning assembly. Find 4 Tower Panels and use this illustration to determine Tops and Bottoms.

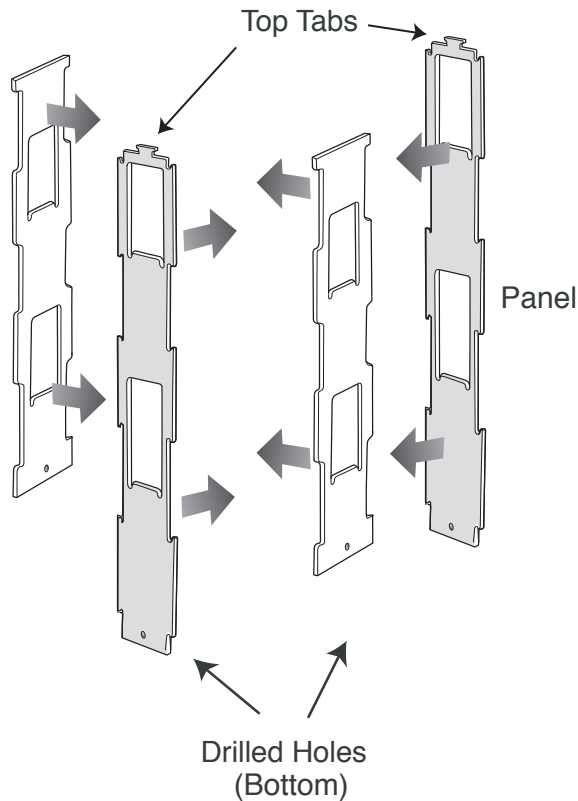

2. Position tabbed and slotted panels as shown. Note the two different pairs of panels go on opposite sides. Gently press tabs into slots and wiggle and flex the tabbed panels to lock them in place.

3. Slightly spread the top tabs apart and drop the Top Cap between the tabs and press together.

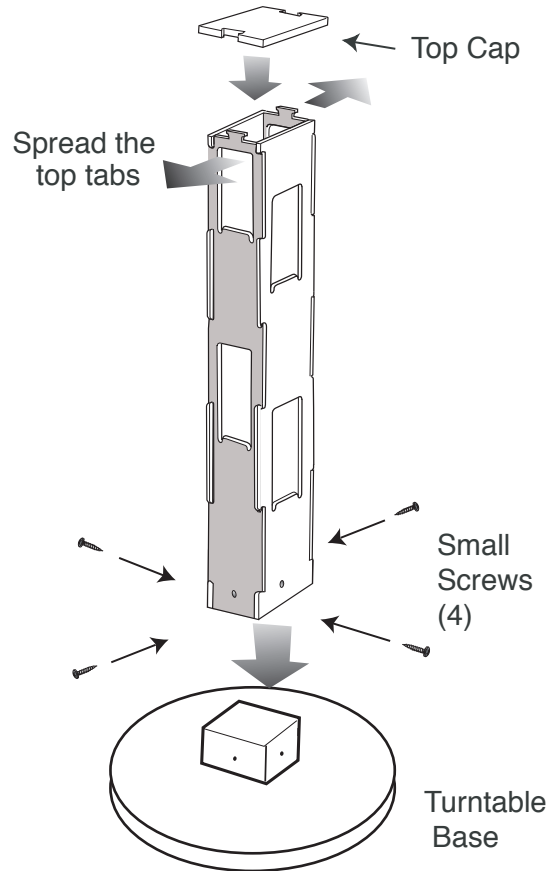

4. Attach the Tower Assembly to the Turntable Base using the 4 small screws.

5. Place the self-adhesive Header Holder clip onto the Top Cap.

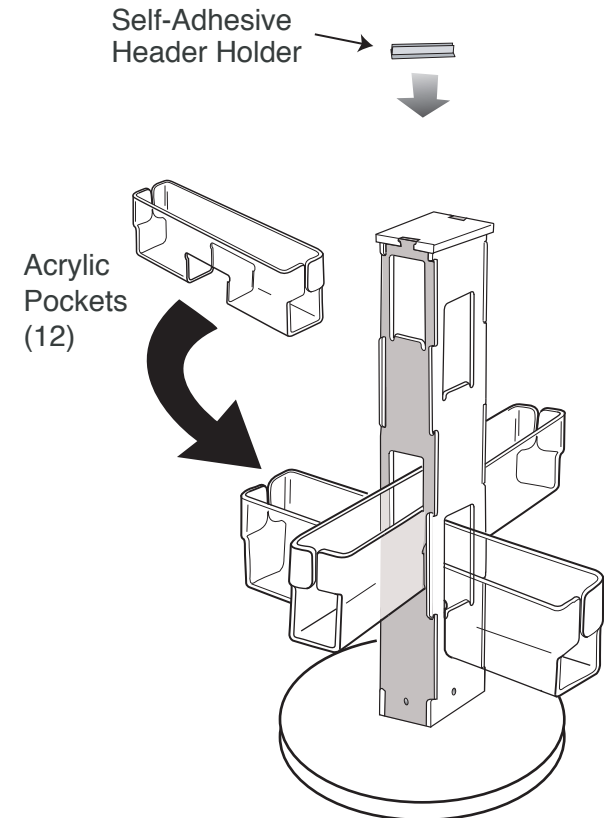

6. Starting from the base, slide the Acrylic Pockets into the holes and press down to lock them in place. on top.